

# All-Pur™ FDA and Food Grade Pumps

PRODUCT BROCHURE

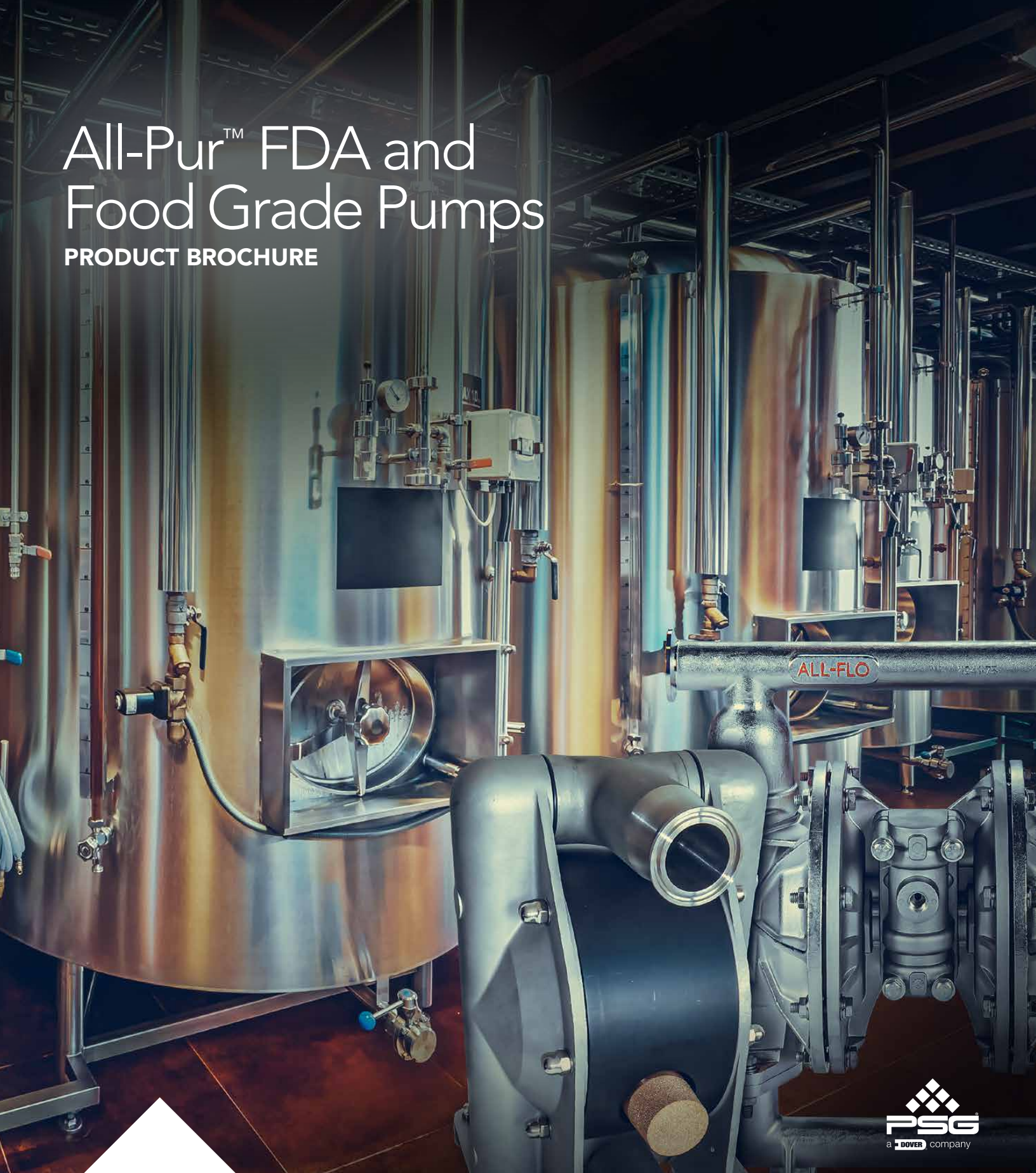

Where Innovation Flows



## All-Pur™ FDA and Food Grade Pumps

All-Flo's All-Pur™ FDA (F Series) and Food Grade (G Series) pumps are ideal for many common food and beverage fluid transfer applications, including beer, wine, cider, and spirits. F Series pumps offer a simple easy to maintain design with electro polished and passivated stainless steel wet end parts. G Series' unique design offers gentle handling, integrated muffler and compact design. Both F Series and G Series pumps are FDA, CE, and ATEX compliant.



### WE PUMP SOLUTIONS™

Since 1986, All-Flo pumps have been built to last. Designed to live up to their name, All-Flo pumps are performance engineered and quality built to provide trouble-free service under the toughest conditions. All of our pumps are 100% factory tested for quality assurance. Our pump's air mechanism features the fewest moving parts of any pump on the market. With fewer parts to wear and breakdown, the result is reduced risk of disruptions in service and reliable operation. When it comes to simplicity of design, see for yourself how our pump stacks up against competitors.



FOOD  
AND BEVERAGE



BEER AND WINE



CBD OIL



LIQUID SUGAR



PET FOOD



## All-Pur™ FDA F Series Pumps

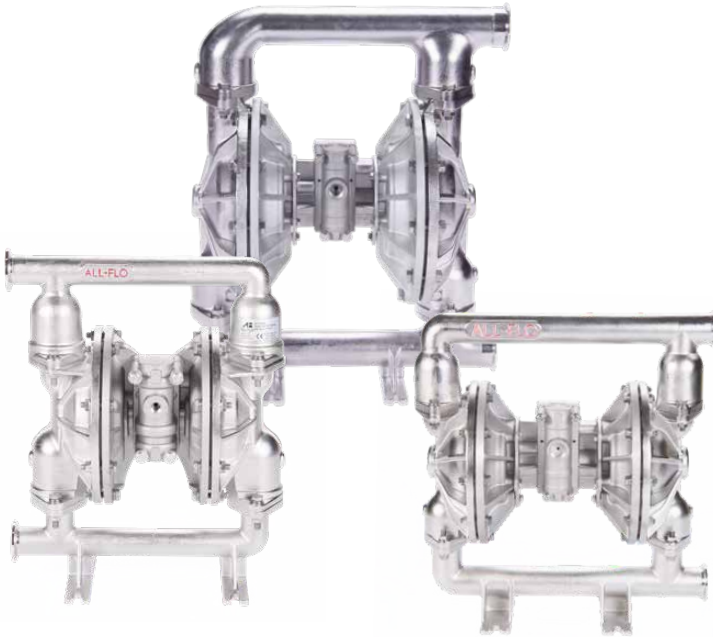

### AVAILABLE SIZES

- 1 in.
- 1-1/2 in.
- 2 in.

### CONNECTION TYPE

- Tri-Clamp®

### CERTIFICATIONS



### BENEFITS

- Shear sensitive
- Self priming
- Wide temperature range
- Simple air motor
- Simple bolted design

## All-Pur™ Food Grade G Series Pumps



### AVAILABLE SIZES

- 3/4 in.
- 1-1/4 in.
- 2 in.

### CONNECTION TYPE

- Tri-Clamp®

### CERTIFICATIONS



### BENEFITS

- Shear sensitive
- Self priming
- Conductive Polyethylene center section
- Integral piston diaphragms
- Adjustable suction and discharge manifolds



## All-Pur™ FDA F Series Pumps Specifications

All-Flo's All-Pur FDA F Series pumps offer a simple easy to maintain design with electro polished and passivated stainless steel wet end parts. F Series pumps are FDA, CE, and ATEX compliant and are perfect for applications requiring a broad range of temperatures.

### Available Materials:

#### LIQUID SECTION MATERIALS

- Electropolished and Passivated 316 Stainless Steel

#### AIR SECTION MATERIALS

- Aluminum
- Stainless Steel
- PTFE Coated Aluminum

#### DIAPHRAGM MATERIALS

- FDA Hytrel®
- PTFE
- FDA Santoprene®

#### VALVE/BALL MATERIALS

- FDA Buna-N
- FDA Santoprene®
- PTFE

#### VALVE SEAT MATERIALS

- Stainless Steel

#### O-RING MATERIALS

- FDA Buna-N
- FDA EPDM
- PTFE

### 1 in. F SERIES PUMP - F100



**Air Inlet:** 1/4" FNPT

**Tri-Clamp Inlet:** 1-1/2"

**Tri-Clamp Discharge:** 1-1/2"

**Max. Pressure:** 120 psi (8.2 bar)

**Max. Temperature:** 225°F (107°C)

**Max. Flow Rate:** 48 gpm (182 lpm)

**Max. Suction Lift:**  
17 ft-H<sub>2</sub>O (5.2 m-H<sub>2</sub>O) Dry  
30 ft-H<sub>2</sub>O (9.1 m-H<sub>2</sub>O) Wet

**Max. Diameter Solids:** 1/4" (6.4 mm)

**Displacement per Stroke:** 0.07 gal (0.28 L)

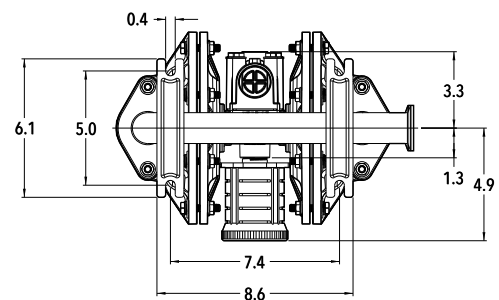
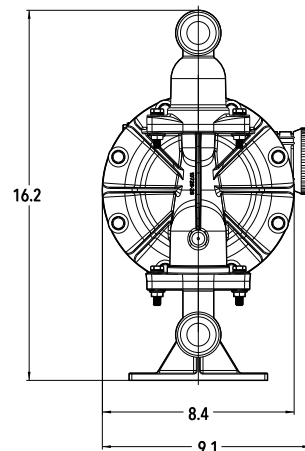
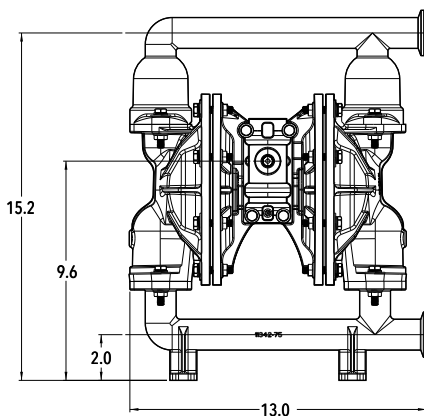

## 1-1/2 in. F SERIES PUMP - F150



Air Inlet: 3/4" FNPT  
 Tri-Clamp Inlet: 2"  
 Tri-Clamp Discharge: 2"  
 Max. Pressure: 120 psi (8.2 bar)  
 Max. Temperature: 225°F (107°C)

Max. Flow Rate: 115 gpm (435 lpm)

Max. Suction Lift:  
 22 ft-H<sub>2</sub>O (6.7 m-H<sub>2</sub>O) Dry  
 31 ft-H<sub>2</sub>O (9.4 m-H<sub>2</sub>O) Wet

Max. Diameter Solids: 1/4" (6.4 mm)

Displacement per Stroke: 0.30 gal (1.15 L)

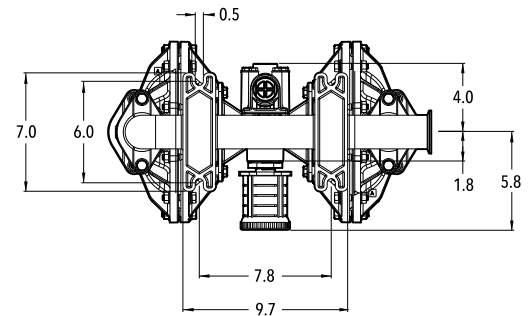
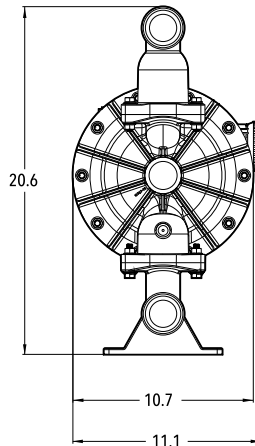
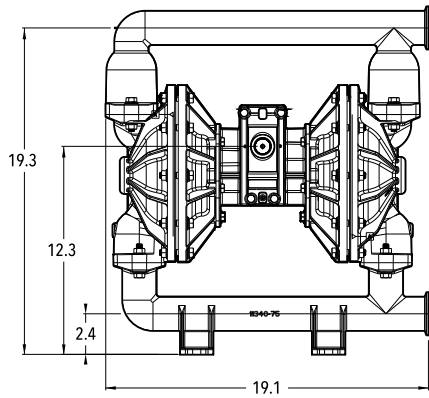

## 2 in. F SERIES PUMP - F200



Air Inlet: 3/4" FNPT  
 Tri-Clamp Inlet: 2-1/2"  
 Tri-Clamp Discharge: 2-1/2"  
 Max. Pressure: 120 psi (8.2 bar)  
 Max. Temperature: 225°F (107°C)

Max. Flow Rate: 190 gpm (719 lpm)

Max. Suction Lift:  
 24.4 ft-H<sub>2</sub>O (7.4 m-H<sub>2</sub>O) Dry  
 31.7 ft-H<sub>2</sub>O (9.7 m-H<sub>2</sub>O) Wet

Max. Diameter Solids: 1/4" (6.4 mm)

Displacement per Stroke: 0.62 gal (2.34 L)

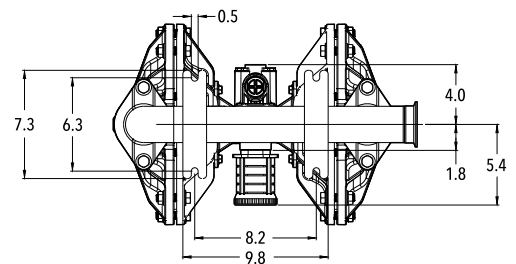
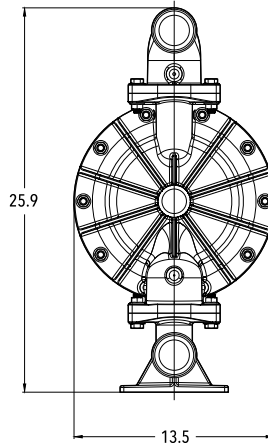
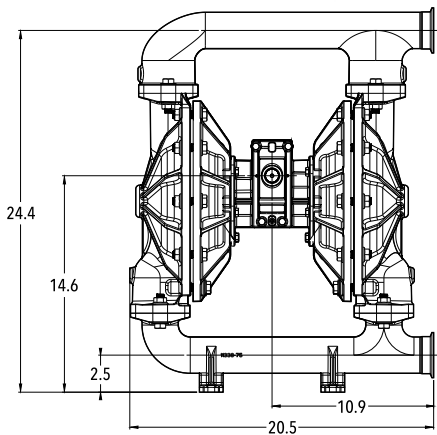



## All-Pur™ Food Grade G Series Pumps Specifications

All-Flo's All-Pur Food Grade G Series pumps offer a unique compact design. Featuring a conductive polyethylene air section, integrated muffler, and optional manual drain valves, G Series pumps are perfect for a variety of food grade applications. G Series pumps are also FDA, CE, ATEX and USP Class VI compliant.

### Available Materials:

#### LIQUID SECTION MATERIALS

- 316 Stainless Steel

#### AIR SECTION MATERIALS

- Conductive Polyethylene

#### DIAPHRAGM MATERIALS

- Integral PTFE
- FDA EPDM

#### VALVE/BALL MATERIALS

- FDA EPDM
- PTFE

#### VALVE SEAT MATERIALS

- N/A (Part of Liquid Section)

#### O-RING MATERIALS

- PTFE
- FDA EPDM
- FKM

#### OPTIONS

- Cycle Counter
- Manual Drain Valves

## 3/4 in. G SERIES PUMP - G075



**Air Inlet:** 1/4" FNPT

**Tri-Clamp Inlet:** 1"

**Tri-Clamp Discharge:** 1"

**Max. Pressure:** 100 psi (7 bar)

**Max. Temperature:** 176°F (80°C)

**Max. Flow Rate:** 20 gpm (75 lpm)

**Max. Suction Lift:**  
6.6 ft-H<sub>2</sub>O (2 m-H<sub>2</sub>O) Dry  
29.5 ft-H<sub>2</sub>O (9 m-H<sub>2</sub>O) Wet

**Max. Diameter Solids:** 7/20" (9 mm)

**Displacement per Stroke:** 0.03 gal (0.1 L)

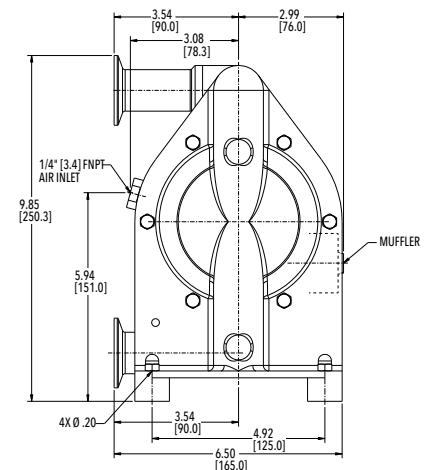
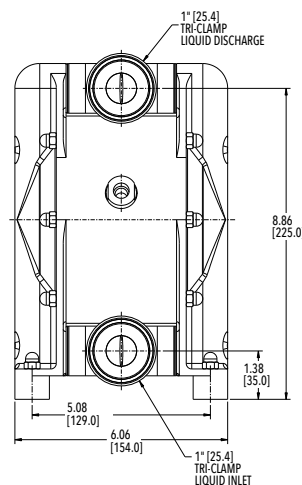

## 1-1/4 in. G SERIES PUMP - G125



Air Inlet: 1/4" FNPT

Tri-Clamp Inlet: 1-1/2"

Tri-Clamp Discharge: 1-1/2"

Max. Pressure: 100 psi (7 bar)

Max. Temperature: 176°F (80°C)

Max. Flow Rate: 40 gpm (150 lpm)

Max. Suction Lift:  
6.6 ft-H<sub>2</sub>O (2 m-H<sub>2</sub>O) Dry  
29.5 ft-H<sub>2</sub>O (9 m-H<sub>2</sub>O) Wet

Max. Diameter Solids: 15/32" (12 mm)

Displacement per Stroke: 0.09 gal (0.34 L)

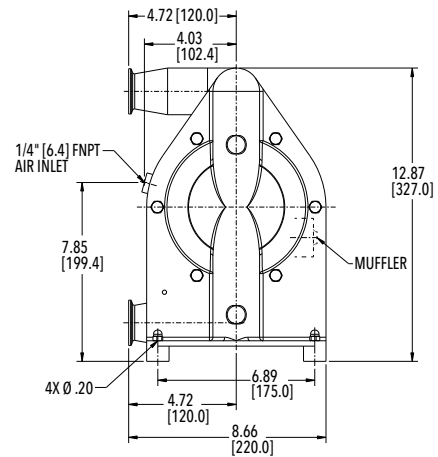
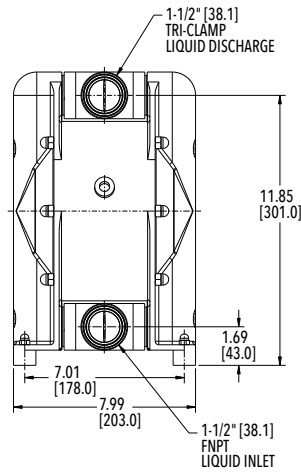

## 2 in. G SERIES PUMP - G200



Air Inlet: 1/2" FNPT

Tri-Clamp Inlet: 2"

Tri-Clamp Discharge: 2"

Max. Pressure: 100 psi (7 bar)

Max. Temperature: 176°F (80°C)

Max. Flow Rate: 106 gpm (400 lpm)

Max. Suction Lift:  
9.8 ft-H<sub>2</sub>O (3 m-H<sub>2</sub>O) Dry  
29.5 ft-H<sub>2</sub>O (9 m-H<sub>2</sub>O) Wet

Max. Diameter Solids: 9/16" (14 mm)

Displacement per Stroke: 0.26 gal (0.98 L)

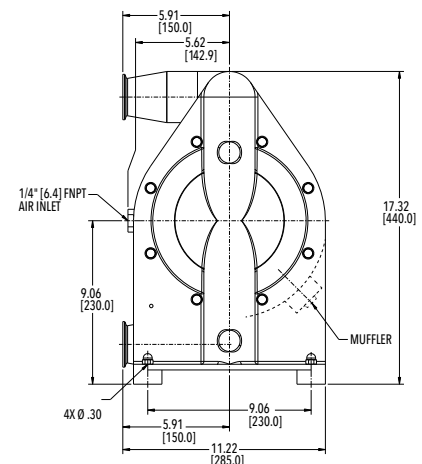
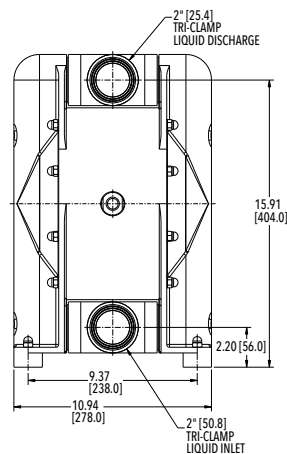



PSG  
22069 Van Buren Street  
Grand Terrace  
CA, 92313-5651  
USA  
P: +1 (440) 354-1700  
F: +1 (440) 354-9466  
[all-flo.com](http://all-flo.com)



Where Innovation Flows

ALF-13000-C-01

Authorized PSG® Partner:

Copyright 2019 PSG®, a Dover company