

# DATA SHEET

## 15 FRAME PLUNGER PUMPS



**Brass Model: 1530.44101**

**Stainless Steel Model: 1531.44101**



Model 1531.44101 Shown  
(Rails sold separately)

SPECIFICATIONS	U.S. Measure	Metric Measure
Flow	15.6 gpm	59 lpm
Pressure Range	100 to 1500 psi	7 to 103 bar
Pump RPM*	1450 rpm	1450 rpm
Inlet Pressure Range	Flooded to 70 psi	Flooded to 4.9 bar
Bore	0.984"	25 mm
Stroke	1.181"	30 mm
Max. Liquid Temperature	240° F	115° C
Above 130°F call Cat Pumps for inlet conditions and elastomer recommendations.		
Crankcase Capacity	42 oz.	1.26 l
Inlet Ports (2)	1" NPT(F)	1" NPT(F)
Discharge Ports (2)	3/4" NPT(F)	3/4" NPT(F)
Pulley Mounting	Either Side	Either Side
Shaft Diameter	1.181"	30 mm
Weight (1530)	55 lbs.	25 kg
Weight (1531)	53 lbs.	24 kg
Dimensions	17.23 x 12.99 x 8.29"	438 x 330 x 210 mm

\* Pump minimum is 100 RPM

### FEATURES

- Field- tested, high pressure triplex pump configured for high temperature TEG (triethylene glycol) applications up to 240°F/115°C. May be used in other high temperature applications with fluids possessing adequate lubrication properties. Contact Cat Pumps for more information.
- Positive displacement technology for optimum energy efficiency.
- Re-configured pump .44101 option consists of following materials:
  - O-Ring material throughout the pump: Fluoropolymer elastomers.
  - Oil filler cap assembly: Brass adapters, chrome-plated steel vented cap.
  - Rear sight gauge assembly: Aluminum sight adapter and stainless steel sight gauge.
  - Seal retainers: Aluminum.
  - Low-pressure seals and V-Packings: Special PTFE blends.

### ELECTRIC HORSEPOWER REQUIREMENTS

FLOW		PRESSURE			PUMP RPM
		psi 1000	psi 1200	psi 1500	
gpm	lpm	bar 69	bar 83	bar 103	1450
15.6	59	10.7	12.8	16.0	

<b>DETERMINING THE PUMP R.P.M.</b>	Rated gpm	=	"Desired" gpm
	Rated rpm	=	"Desired" rpm
<b>DETERMINING THE REQUIRED H.P.</b>	gpm x psi	=	Electric Brake
	1460	=	H. P. Required
<b>DETERMINING MOTOR PULLEY SIZE</b>	Motor Pulley O.D.	=	Pump Pulley O.D.
	Pump rpm	=	Motor rpm

See complete Drive Packages [Incls: Pulleys, Belts, Hubs, Key] Tech Bulletin 003. Refer to pump **Service Manual** for repair procedure and additional technical information.

# PARTS LIST

ITEM	PART NUMBER	MATL	PART NUMBER	MATL	DESCRIPTION	QTY
	<b>1530.44101</b>		<b>1531.44101</b>			
5	<b>125824</b>	STCP R	<b>92538</b>	S	Screw, HHC Sems (M6x16)	8
8	43496	AL	43496	AL	Cover, Bearing (See Tech Bulletin 118)	2
9	815281	FBR	815281	FBR	Shim, Split 2-Pc	3
10	76340	FPM	76340	FPM	O-Ring, Bearing Cover - 75D	2
11	76491	FPM	76491	FPM	Seal, Oil, Crankshaft - 70D	2
12	814800	S	814800	S	Shim, Split, 2-Pc	2
15	39060	STL	39060	STL	Bearing, Roller	2
20	48600	TNM	48600	TNM	Rod, Connecting Assembly	3
25	43494	FCM	43494	FCM	Crankshaft, Dual-End (M30)	1
31	76411	BB	76411	BB	Adapter, [3/4" NPT(F)]	1
32	992623	BB	992623	BB	Nipple, Close [3/4" NPT(M)]	1
33	76331	STCP	76331	STCP	Cap, Vented	1
36	76792	SS	76792	SS	Gauge, Sight	1
37	76791	AL	76791	AL	Adapter, Sight	1
38	44428	NBR	44428	NBR	Gasket, Flat, Adapter - 80D	1
40	<b>126541</b>	STCP R	<b>92542</b>	S	Screw, HHC Sems (M6x20)	4
48	25625	STCP	25625	STCP	Plug, Drain (1/4"x19BSP)	1
49	30322	FPM	30322	FPM	O-Ring, Drain Plug	1
50	43491	AL	43491	AL	Cover, Rear (See Tech Bulletin 118)	1
51	76834	FPM	76834	FPM	O-Ring, Rear Cover - 75D	1
53	115471	AL	115471	AL	Crankcase (Includes Guidepin) (See Tech Bulletin 118)	1
64	43507	CM	43507	CM	Pin, Crosshead	3
65	<b>48228</b>	SHS	<b>48360</b>	SSHS	Rod, Plunger	3
69	126592	STCP R	126592	STCP R	Washer, Oil Seal	3
70	76500	FPM	76500	FPM	Seal, Oil Crankcase	3
75	43506	S	43506	S	Slinger, Barrier	3
90	48606	CC	48606	CC	Plunger, Ceramic (M25x92)	3
95	—	—	<b>89651</b>	SS	Stud, Plunger Retainer (M6x70)	3
96	43235	PTFE	43235	PTFE	Back-Up Ring, Plunger Retainer	3
97	14160	FPM	14160	FPM	O-Ring, Plunger Retainer - 80D	3
98	<b>45891</b>	CU	<b>44041</b>	SS	Gasket, Plunger Retainer	3
99	<b>104360</b>	S	<b>44031</b>	SS	Retainer, Plunger	3
100	769509	AL	769509	AL	Retainer, Seal	3
106	76086	ST2	76086	ST2	Seal, LPS w/S-Spg	3
110	<b>48608</b>	FBB	<b>48683</b>	SS	Manifold, Inlet	1
112	11719	FPM	11719	FPM	O-Ring, Inlet Manifold	3
117	<b>126515</b>	STCP R	<b>87952</b>	S	Screw, HSH (M10x55)	4
126	<b>48538</b>	BB	<b>76667</b>	SS	Adapter, Female	3
127	703050	SFTB	703050	SFTB	V-Packing	6
128	<b>48539</b>	BB	<b>113025</b>	SS	Adapter, Male	3
141	48672	SS	48672	SS	Spring, Coil	18
142	<b>48550</b>	BB	<b>48670</b>	SS	Spacer, w/Coil Springs	3
155	14183	FPM	14183	FPM	O-Ring, Spacer	6
156	28243	PTFE	28243	PTFE	Back-Up Ring, Spacer	6
162	44614	PTFE	44614	PTFE	Back-Up Ring, Seat	6
163	14330	FPM	14330	FPM	O-Ring, Seat - 70D	6
164	<b>48596</b>	S	<b>48688</b>	SS	Seat	6
166	48686	SS	48686	SS	Valve	6
167	48687	SS	48687	SS	Spring, Valve	6
168	44735	PVDF	44735	PVDF	Retainer, Spring	6
170	44794	SS	44794	SS	Washer, Spring Retainer	6
171	48689	SS	48689	SS	Spring, Coil	6
172	14183	FPM	14183	FPM	O-Ring, Valve Plug	6
174	<b>48597</b>	FBB	<b>49294</b>	SS	Plug, Valve	6
185	<b>48610</b>	FBB	<b>48685</b>	SS	Manifold, Discharge	1
188	<b>126519</b>	STCP R	<b>89981</b>	S	Screw, HSH (M12x70)	6

## Repair Kits/Parts and Optional Parts/Accessories On Page 4

**Bold part numbers are unique to a particular pump model.**

R Components comply with RoHS Directive.

View Tech Bulletins 002, 003, 024, 035, 036, 043, 053, 074, 083, 095 and 118 for additional information.

MATERIAL CODES (Not Part of Part Number): AL=Aluminum BB=Brass CC=Ceramic CM=Chrome-moly CU=Copper FBB=Forged Brass FBR=Fiber FCM=Forged Chrome-moly  
 FPM=Fluorocarbon NBR=Medium Nitrile (Buna-N) PVDF=Polyvinylidene Fluoride PTFE= Pure Polytetrafluoroethylene S=304SS SFTB=Special Blend PTFE Black SHS=304SS/High Strength  
 SS=316SS SSS=316SS/High Strength ST2=Special PTFE 2 STCP=Steel/Chrome Plated STL=Steel TNM=Special High Strength

# EXPLODED VIEW

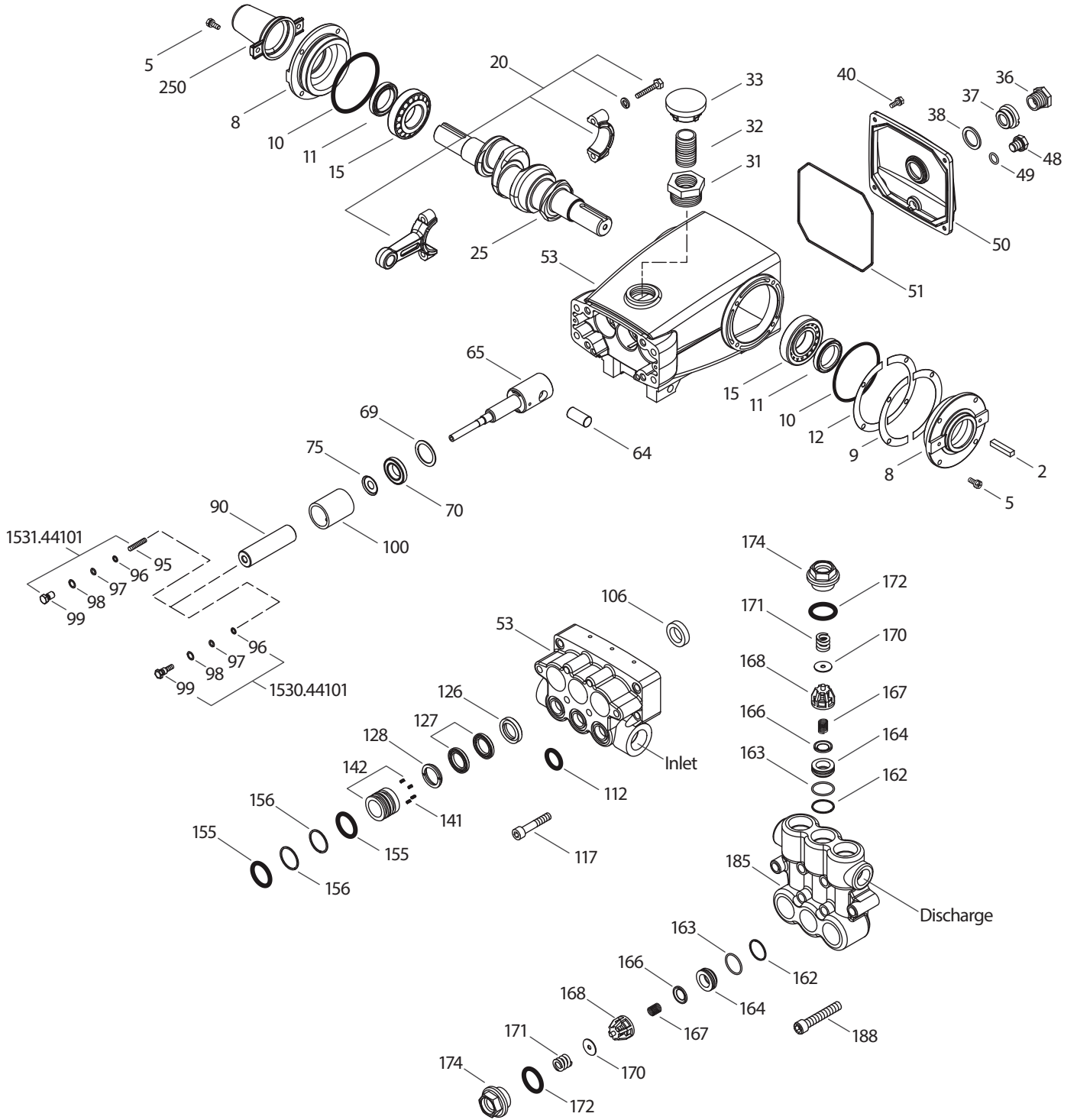

Model  
 Brass - 1530.44101  
 Stainless Steel - 1531.44101  
 May 2016

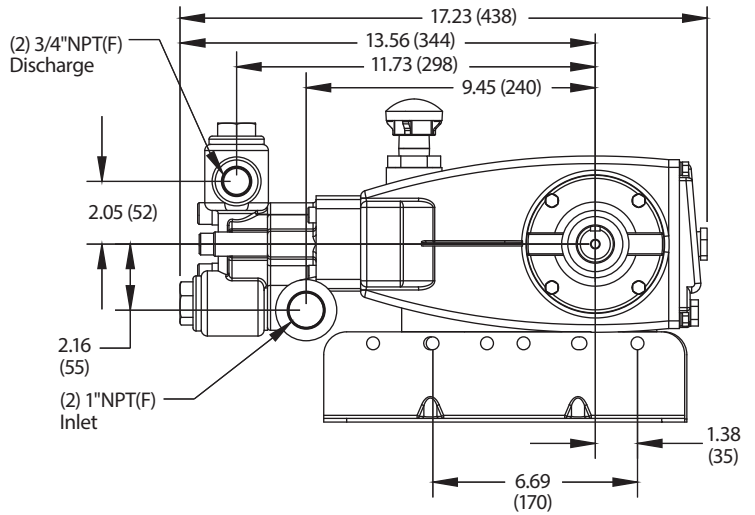
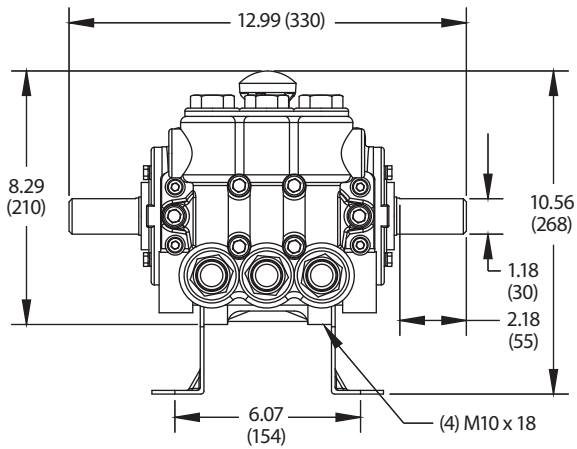

## REPAIR KITS AND PARTS

PART NUMBER	DESCRIPTION	QTY
76272 (1530.44101, 1531.44101)	Kit, Seal (Includes Items 97, 106, 112, 127, 155 and 156)	1
76293 (1530.44101)	Kit, Valve (Includes Items 162, 163, 164, 166, 167, 168, 170 and 172)	2
76281 (1531.44101)	Kit, Valve (Includes Items 162, 163, 164, 166, 167, 168 170 and 172)	2
6107	Oil, Bottle (21 oz.) ISO 68 Hydraulic	2
30067/990036	Key (M8 x 7.5 x 25) / (M8 x 7 x 40)	1
6119	Lubricant, Antiseize (2 oz.) – Model 1531.44101	1

## OPTIONAL PARTS AND ACCESSORIES

PART NUMBER	DESCRIPTION	QTY
7022/ 7022.100	Regulator (Primary Pressure Control)	1
7537.0110/ 7531.0110	Unloader (Primary Pressure Control)	1
7537.1110/ 7531.0110	Relief Valve (Secondary Pressure Control)	1
7537.1110/ 7531.1110	Pop-Off Valve (Secondary Pressure Control)	1
6073	Pressure Gauge	1
6013	Accumulator	1
30613	Mounting Rails	1
76334	Kit, Oil Indicator (3/8" x 24") See Individual Data Sheet	1
34334	Kit, Oil Drain (3/8" x 24") See Individual Data Sheet	1
816762.44101/ 816783.44101	Complete Head	1
30696	Pliers (Reverse)	1

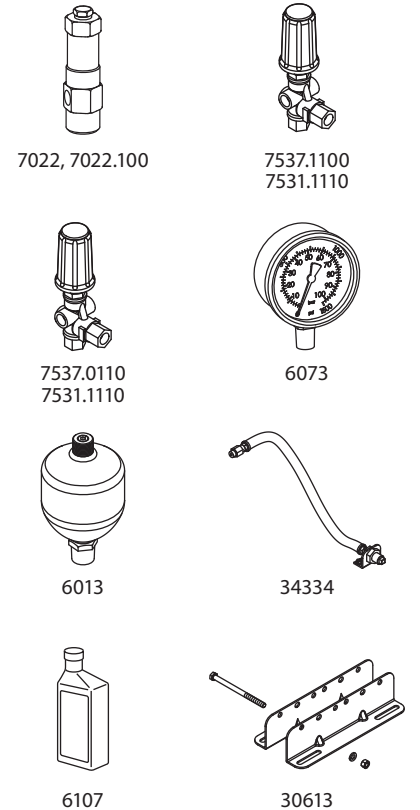

### ⚠ CAUTIONS AND WARNINGS

All High Pressure Systems require a primary pressure regulating device (i.e. regulator, unloader) and a secondary pressure relief device (i.e. pop-off valve, relief valve). Failure to install such relief devices could result in personal injury or damage to pump or property. Cat Pumps does not assume any liability or responsibility for the operation of a customer's high pressure system.

Read all CAUTIONS and WARNINGS before commencing service or operation of any high pressure system. The CAUTIONS and WARNINGS are included in each service manual and with each Accessory Data sheet. CAUTIONS and WARNINGS can also be viewed online at [www.catpumps.com/cautions-warnings](http://www.catpumps.com/cautions-warnings) or can be requested directly from Cat Pumps.

### WARRANTY

View the Limited Warranty on-line at [www.catpumps.com/warranty](http://www.catpumps.com/warranty).



### CAT PUMPS

1681 - 94TH LANE N.E. MINNEAPOLIS, MN 55449-4324  
 PHONE (763) 780-5440 — FAX (763) 780-2958  
 e-mail: [techsupport@catpumps.com](mailto:techsupport@catpumps.com)  
[www.catpumps.com](http://www.catpumps.com)