

Optional Oilers Shown

FEATURES

- Triplex Uniflow design provides a smooth, low-pulsation flow with strong suction capabilities.
- Hard chrome-plated 304S cylinders (optional 316SS) and sleeves provide long life with mild liquids within a range of 5-9 PH.
- Optimal 316 stainless steel manifolds for added strength and corrosion resistance.
- Optimal FPM elastomers for liquid compatibility.

COMMON SPECIFICATIONS

RPM.....	500 rpm	(500 rpm)
Stroke.....	2.461"	(62.5 mm)
Crankcase Capacity.....	10 Qts.	(9.46 l)
Maximum Liquid Temperature.....	160°F	(71°C)
Above 130°F call CAT PUMPS for inlet conditions and elastomer recommendations.		
Inlet Pressure Range.....	-8.5 to +40 psi	(-0.6 to +2.8 bar)
Inlet Port (1).....	2" NPTF	(2" NPTF)
Discharge Ports (3).....	1-1/4" NPTF	(1-1/4" NPTF)
Pulley Mounting	Either Side	(Either Side)
Shaft Diameter	1.772"	(45 mm)
Weight	235 lbs.	(107 kg)
Dimensions.....	31.4x24.0x12.05"	(796.5x610x306 mm)

⚠ CAUTIONS AND WARNINGS

All High Pressure Systems require a primary pressure regulating device (i.e. regulator, unloader) and a secondary pressure relief device (i.e. pop-off valve, relief valve). Failure to install such relief devices could result in personal injury or damage to pump or property. CAT PUMPS does not assume any liability or responsibility for the operation of a customer's high pressure system.

Read all CAUTIONS and WARNINGS before commencing service or operation of any high pressure system. The CAUTIONS and WARNINGS are included in each service manual and with each Accessory Data sheet. CAUTIONS and WARNINGS can also be viewed online at www.catpumps.com/cautions-warnings or can be requested directly from CAT PUMPS.

WARRANTY

View the Limited Warranty on-line at www.catpumps.com/warranty.

60 Frame Piston Pumps

Brass Models

6020 6040

Stainless Steel Models

6021 6041

SPECIFICATIONS

MODEL 6020, 6021

Flow.....	60 gpm	(227 lpm)
Pressure Range.....	100 to 1000 psi	(7 to 70 bar)
Bore	2.205"	(56 mm)

MODEL 6040, 6041

Flow.....	40 gpm	(151 lpm)
Pressure Range.....	100 to 1500 psi	(7 to 105 bar)
Bore	1.811"	(46 mm)

ELECTRIC HORSEPOWER REQUIREMENTS

MODEL	FLOW		PRESSURE				RPM	DRIVE
			psi 800	psi 1000	psi 1200	psi 1500		
	U.S. gpm	lpm	bar 55	bar 70	bar 85	bar 105		
6020,	60	227	32.9	41.1	N/A	N/A	500	Consult Cat Pumps for Pump & Motor Pulley Sizes
6021	50	189	27.4	34.3	N/A	N/A	417	
	40	151	22.0	27.4	N/A	N/A	333	
6040	40	151	22.0	27.4	32.9	41.1	500	Pump & Motor Pulley Sizes
6041	36	136	19.8	24.7	29.7	37.0	478	
	30	114	16.5	20.6	24.7	30.9	375	

**DETERMINING
THE PUMP R.P.M.**

$$\frac{\text{Rated gpm}}{\text{Rated rpm}} = \frac{\text{"Desired" gpm}}{\text{"Desired" rpm}}$$

**DETERMINING
THE REQUIRED H.P.**

$$\frac{\text{gpm} \times \text{psi}}{1460} = \text{Electric Brake
H. P. Required}$$

**DETERMINING
MOTOR PULLEY SIZE**

$$\frac{\text{Motor Pulley O.D.}}{\text{Pump R.P.M.}} = \frac{\text{Pump Pulley O.D.}}{\text{Motor rpm}}$$

See complete Drive Packages [Incls: Pulleys, Belts, Hubs, Key] Tech Bulletin 003. Refer to pump **Service Manual** for repair procedure and additional technical information.

PARTS LIST

ITEM	PART NUMBER		DESCRIPTION		QTY	
	6020,6021	MATL	6040, 6041	MATL		
2	43048	STL	43048	STL	Key (M14x9x90)	1
5	126532	STCP R	126532	STCP R	Screw, HH (M10x40)	8
6	126231	STCP R	126231	STCP R	Lockwasher (M10)	8
7	126574	STZP R	126574	STZP R	Washer, Flat (M10)	8
8	29443	AL	29443	AL	Case, Bearing, Outer	2
10	29444	NBR	29444	NBR	O-Ring, Bearing Case - 70D	2
11	11443	NBR	11443	NBR	Seal, Oil, Crankshaft - 70D	2
15	29441	STL	29441	STL	Bearing, Roller	2
16	29442	STL	29442	STL	Case, Bearing, Inner	2
17	29444	NBR	29444	NBR	O-Ring, Bearing Case - 70D	2
20	126612	BBHS	126612	BBHS	Rod, Connecting (Incls: 21, 22)	3
21	126560	STCP R	126560	STCP R	Washer, Locking	3
22	126593	STCP R	126593	STCP R	Washer, Shim	6
25	29440	FCM	29440	FCM	Crankshaft, (M65.5)	1
31	828710	—	828710	—	Protector, Oil Cap w/Foam Gasket	1
32	43211	ABS	43211	ABS	Cap, Oil Filler	1
33	14177	NBR	14177	NBR	O-Ring, Cap - 70D	1
34	126743	STCP R	126743	STCP R	Bolt, Eye (M12) (For lifting pump only)	1
38	129343	RBR	129343	RBR	Gasket, Flat Flex	1
39	27769	ABS	27769	ABS	Dipstick	1
40	80288	STZP	80288	STZP	Screw, HH (M10x30)	8
	126531	STCP R	126531	STCP R	Screw, HH (M10x30)	8
41	126231	STCP R	126231	STCP R	Lockwasher (M10)	8
42	126574	STZP R	126574	STZP R	Washer, Flat (M10)	8
48	25625	STCP	25625	STCP	Plug, Drain (1/4x19BSP)	1
49	23170	NBR	23170	NBR	O-Ring, Drain Plug - 70D	1
50	29438	AL	29438	AL	Cover, Rear	1
51	129386	NBR	129386	NBR	Gasket, Rear Cover	1
53	45303	AL	45303	AL	Crankcase w/Guide Pins (Incls: 34, 54)	1
54	43282	S	43282	S	Pin, Guide	3
55	126554	STCP R	126554	STCP R	Stud (M16x72)	4
	89615	S	89615	S	Stud (M16x70)	3
64	29481	CM	29481	CM	Pin, Crosshead	3
65	43809	SSZZ	43809	SSZZ	Rod, Piston	3
69	126588	STCP R	126588	STCP R	Washer, Oil Seal	3
70	29454	NBR	29454	NBR	Seal, Oil, Crankcase - 80D	3
75	29340	S	29340	S	Slinger, Barrier	3
77	13967	NBR	13967	NBR	O-Ring, Sleeve	6
	14308	FPM	14308	FPM	O-Ring, Sleeve	6
80	43129	SCP	43129	SCP	Sleeve (M25)	3
	43271	S	43271	S	Sleeve (M25) (Unchromed)	3
	700923	SS	700923	SS	Sleeve (M25)	3
81	29455	PTFE	29455	PTFE	Back-up-Ring, Sleeve	3
100	29456	AL	29456	AL	Retainer, Seal	3
101	43136	—	43136	—	Wick, Oil (M25)	3
106	43130	NBR	43130	NBR	Seal, LPS Ungreased (M25)	3
	43132	FPM	43132	FPM	Seal, LPS Ungreased (M25)	3
110	43283	BBCP	43283	BBCP	Manifold, Inlet	1
	29805	SS	29805	SS	Manifold, Inlet	1
117	88902	STZP	88902	STZP	Stud (M16x277)	4
119	29460	S	43200	S	Valve, Inlet	3
	700942	SS	—	—	Valve, Inlet	3
133	29461	NBR	43201	NBR	Cup-Piston Assy w/S-Piston	3
	76609	ST4	31305	ST4	Cup-Piston Assy w/FPM O-Ring (1000 PSI Max)	3
135	29463	S	29463	S	Spacer, Piston	3
136	29464	S	43203	S	Retainer, Piston	3
137	44272	SS	44272	SS	Washer, Conical (M14)	3
138	29465	S	29465	S	Nut, Slotted (M14)	3
139	29354	S	29354	S	Cotterpin (M2.5x25)	3
143	12392	NBR	12392	NBR	O-Ring, Cylinder - 70D	6
	13279	FPM	13279	FPM	O-Ring, Cylinder - 70D	6
150	29466	SCP	43204	SCP	Cylinder	3
	43279	S	43392	S	Cylinder (Unchromed)	3
	700921	SS	700922	SS	Cylinder	3
153	23116	PTFE	23116	PTFE	Back-up-Ring, Cylinder	3
162	43206	PTFE	43206	PTFE	Back-up-Ring, Seat	3
163	29471	NBR	29471	NBR	O-Ring, Seat	3
	29479	FPM	29479	FPM	O-Ring, Seat	3
164	43205	S	43205	S	Seat (Flat Valve)	3
166	29468	S	29468	S	Valve (Flat Valve)	3
167	29469	S	29469	S	Spring	3
168	43143	S	43143	S	Retainer, Spring	3
185	29472	BBCP	29472	BBCP	Manifold, Discharge	1
	29806	SS	29806	SS	Manifold, Discharge	1
186	126569	STCP R	126569	STCP R	Lockwasher (M16)	12
187	29473	STCP	29473	STCP	Bolt (M16x225)	4
194	88853	STCP	88853	STCP	Nut, Hex (M16)	8
	126525	STCP R	126525	STCP R	Nut, Hex (M16)	4
	81291	S	81291	S	Nut, Hex (M16)	4
196	29476	BBCP	29476	BBCP	Plug (1-1/4" NPT)	1
197	22187	BBCP	22187	BBCP	Plug (3/8" NPT)	1
	701078	SS	701078	SS	Plug (3/8" NPT)	1

EXPLODED VIEW

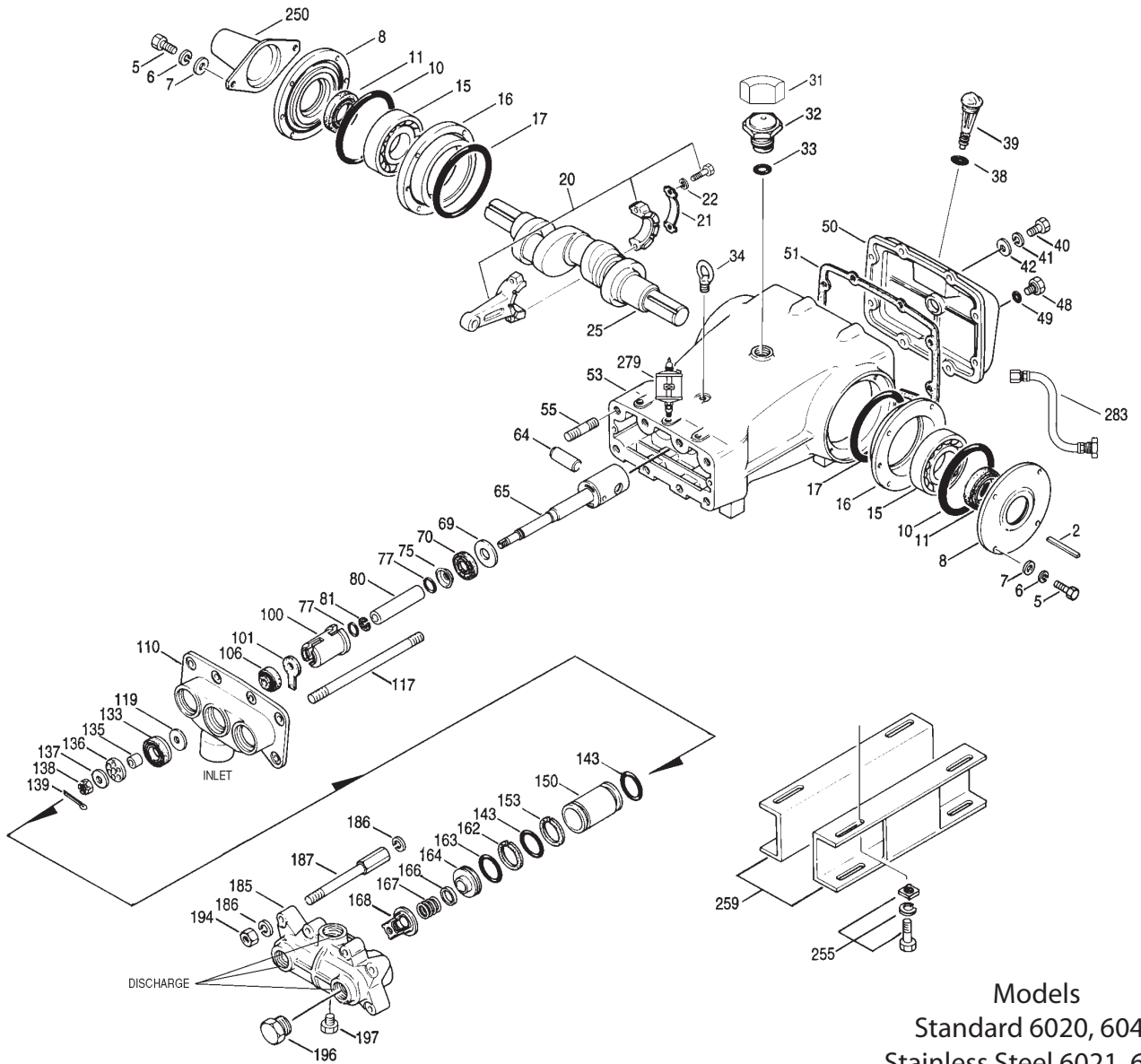

Models
Standard 6020, 6040
Stainless Steel 6021, 6041
July 2012

	6020	MATL	6040	MATL	DESCRIPTION	QTY
250	29445	AL	29445	AL	Protector, Shaft (Included with Pump)	1
255	33243	STZP	33243	STZP	Mount, Direct (Included with Pump)	1
259	29477	STZP	29477	STZP	Mounting, Rail (Included 2 with Pump)	2
279	30429	STZP	30429	STZP	Oilers (10 oz.)	3
281	30969	—	30969	—	Oilers, Glass (10 oz.)	3
282	10070	NBR	10070	NBR	Gasket, Oiler (10 oz.)	3
283	34314	—	34314	—	Kit, Oil Drain	1
300	30440	NBR	30433	NBR	Kit, Cup (Incls: 133,139,143)	1
	700973	NBR*	—	—	Kit, Cup (Incls: 133,139,143) (6021 Only)	1
302	30439	NBR	—	—	Kit, Piston (Incls: 119,133,135,136,137,138,139,143)	1
	701039	NBR	—	—	Kit, Piston (Incls: 119,133,136,137,138,139,143) (6021 Only)	1
305	30485	NBR	30485	NBR	Kit, Sleeve & Seal (Incls: 75,77,80,81,101,106,139)	1
306	30484	NBR	30484	NBR	Kit, Seal (Incls: 101,106,139)	1
310	30441	NBR	30441	NBR	Kit, Valve (Incls: 143,162,163,164,166,167,168)	1
—	76441	FPM	76441	FPM	Kit, Valve (Incls: 143,162,163,164,166,167,168)	1
—	717500	SS	714500	SS	C.A.T. (Captive Acceleration Tube)	1
—	717508	SS	714508	SS	Adapter (2 per C.A.T.) (See Data Sheet for complete selection)	2
—	6105	—	6105	—	Oil, Twin Pack (2-2.5 gal) ISO 68 Hydraulic (Fill to specified crankcase capacity prior to start-up)	1

Bold part numbers are unique to a particular pump model. *Italics are optional items.* R Components comply with RoHS Directive. See Tech Bulletins 002, 003, 024, 035, 036, 074, 077, 083 and 084 for additional information.

C. A.T. highly recommended for pressurized inlet, R.O. and Industrial applications.

MATERIAL CODES (Not Part of Part Number): ABS=ABS Plastic AL=Aluminum BBP=Brass/Chrome Plated BBHS=Brass/High Strength CM=Chrome-Moly FCM=Forged Chrome-Moly FPM=Fluorocarbon NBR=Medium Nitrile (Buna-N) PTFE=Pure Polytetrafluoroethylene RBR=Rubber S=304SS SCP=304SS/Chrome Plated SS=316SS SSZZ=316SS/Zamak STCP=Steel/Chrome Plated STL=Steel STZP=Steel/Zinc Plated TG=PTFE Graphite Compound (GIT) ST4=Special PTFE4

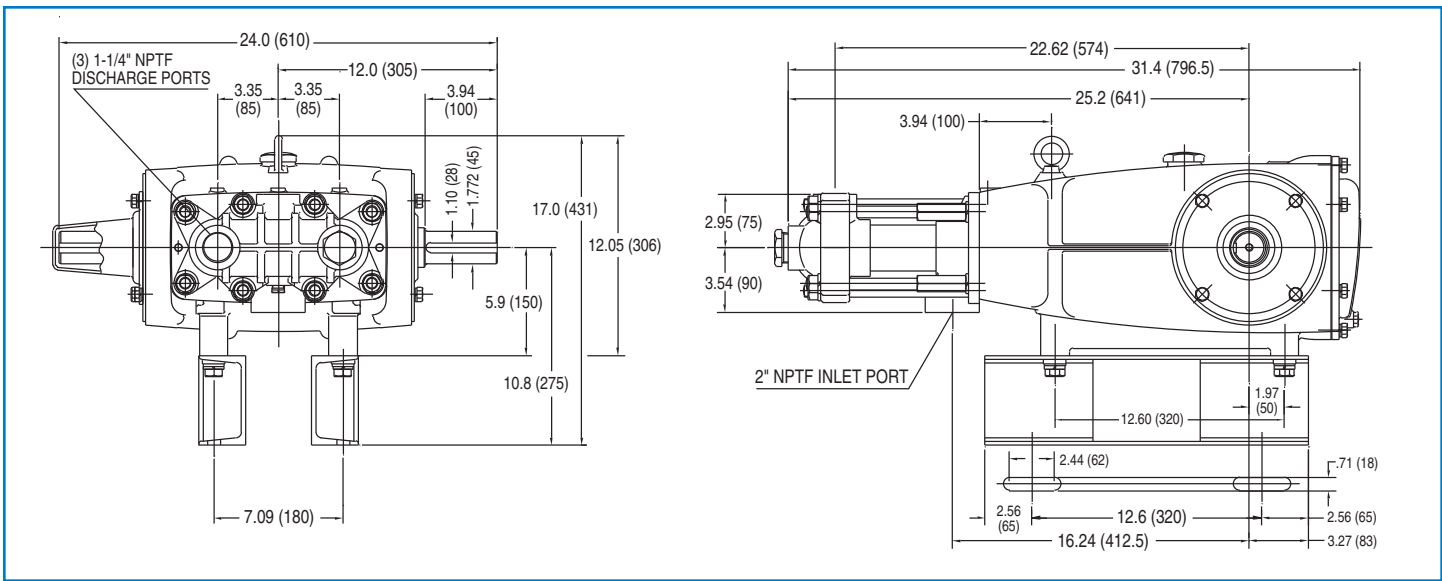

Models 6020, 6021, 6040, 6041

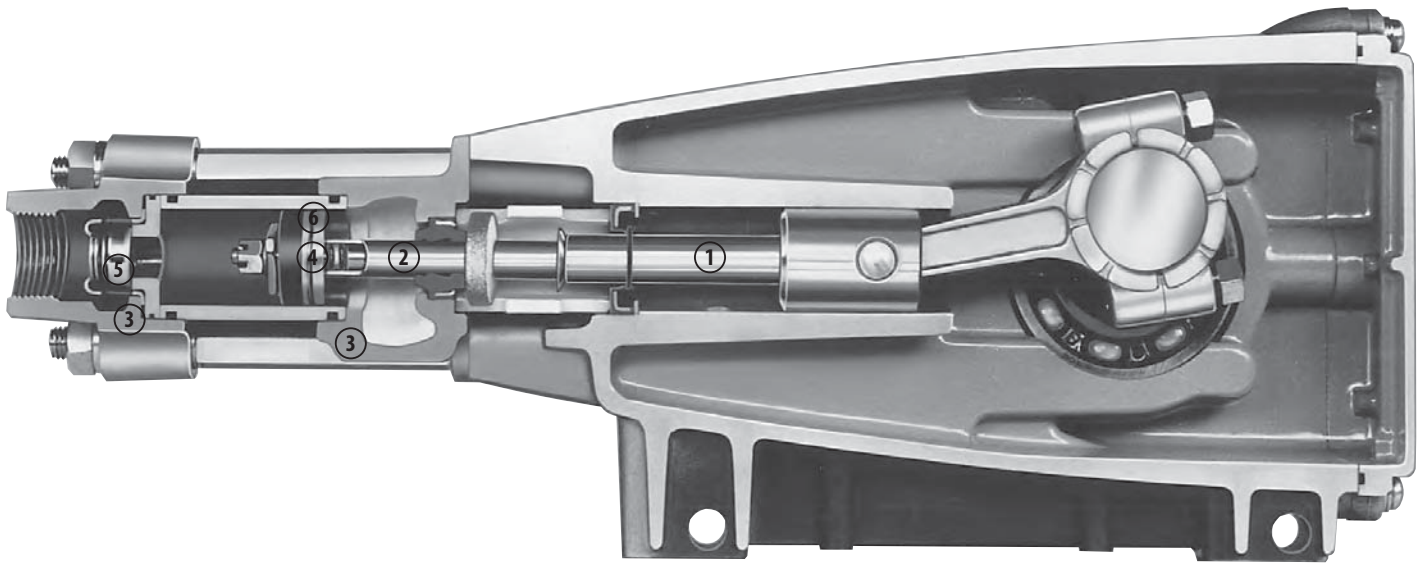

- 1** The **patented stepped piston rod** with stainless steel **sleeves** provides a durable wear surface and easy wet-end servicing.
- 2** The **cylinder** and **sleeve** wear surfaces are hard chrome-plated 304 stainless steel for longer service life.
- 3** **Manifolds** are of high tensile strength chrome-plated brass or 316 stainless steel for special corrosion resistance.
- 4** 100% wet **cup/seal** design adds to service life by allowing pumped liquids to cool and lubricate the elastomers on both sides.
- 5** 304 stainless steel **valves, seats, and springs** provide corrosion-resistance, ultimate seating and extended life.
- 6** Mechanically actuated **inlet valves** provide strong lift and easy prime.



CAT PUMPS
 1681 - 94TH LANE N.E. MINNEAPOLIS, MN 55449-4324
 PHONE (763) 780-5440 — FAX (763) 780-2958
 e-mail: techsupport@catpumps.com
 www.catpumps.com