



Pressure Sensitive Multiple Gun Regulating Unloaders

Models **7590**
7592

FEATURES

- Maintains full system pressure while running in by-pass without full load on pump.
- Offers pump protection against pressure fluctuations and system changes.
- Minimum pressure fluctuations with alternating use of multiple guns.
- Easy external pressure adjustment with locking nut to prevent over pressure.
- Lightweight flow through design for compact installation.

SPECIFICATIONS

MODEL 7590	U.S. Measure	Metric Measure
Flow Range	10-52 gpm	(38-200 lpm)
Pressure Range.....	400-2175 psi	(30-150 bar)

MODEL 7592	U.S. Measure	Metric Measure
Flow Range	10-52 gpm	(38-200 lpm)
Pressure Range.....	450-2500 psi	(31-175 bar)

COMMON SPECIFICATIONS

Inlet Port (Flush Back)	1" NPTF	(1" NPTF)
Discharge Port (Extended Front)	1" NPTF	(1" NPTF)
By-Pass Port (Flush Bottom)	1" NPTF	(1" NPTF)
Maximum Operating Temperature:		
Standard Buna o-rings.....	140°F	(60°C)
Standard Buna o-rings (intermittent)	195°F	(90°C)
Optional FPM o-rings.....	240°F	(116°C)
Weight	4.46 lbs.	(2.02 kg)
Dimensions.....	8.85 x 5.08 x 1.625"	(225 x 129 x 41 mm)

⚠ CAUTIONS AND WARNINGS

All High Pressure Systems require a primary pressure regulating device (i.e. regulator, unloader) and a secondary pressure relief device (i.e. pop-off valve, relief valve). Failure to install such relief devices could result in personal injury or damage to pump or property. CAT PUMPS does not assume any liability or responsibility for the operation of a customer's high pressure system.

Read all CAUTIONS and WARNINGS before commencing service or operation of any high pressure system. The CAUTIONS and WARNINGS are included in each service manual and with each Accessory Data sheet. CAUTIONS and WARNINGS can also be viewed online at www.catpumps.com/cautions-warnings or can be requested directly from CAT PUMPS.

WARRANTY

View the Limited Warranty on-line at www.catpumps.com/warranty.

Unloader is stamped with a European safety pressure. Use only at above specifications to assure proper unloader life and performance.

For Relief Valve version add .100 to unloader model number.

**Read all CAUTIONS and WARNINGS before commencing
service or operation of any high-pressure system**

SELECTION

This is a pressure sensitive regulating unloader. Designed for systems with single or multiple pumps, solenoid (gate) valves, nozzles, standard or "weep" guns.

Note: For multiple pump systems, it is best to use a pressure regulator not a pressure sensitive regulating unloader.

This pressure sensitive regulating unloader should meet both the desired system flow (combined nozzle flow rate requirement) and the desired system pressure.

CAUTION: When operating multiple guns, be certain to establish a minimum of 10 GPM per gun to avoid cycling of the unloader.

Note: Operation below the minimum flow of the unloader causes the unloader to cycle. Operation above the maximum flows of the unloader causes premature unloader wear, cycling and prevents attaining desired system pressure.

INSTALLATION

This unloader operates properly when mounted in any direction, however, it is preferred to keep the plumbing to a minimum and the pressure adjuster/adjusting handle easily accessible. The best mounting location is directly on the pump discharge manifold head.

The inlet connection on this unloader is a 1" NPTF sized port and is located on the back side. There is an arrow and the word IN cast into the body indicating the direction of flow. Fluid from the discharge of the manifold goes through this connection.

The discharge connection on this unloader is a 1" NPTF sized port and is located on the front side (hex end). There is an arrow and the word OUT cast into the body indicating the direction of flow. Plumbing for the spray guns, solenoid (gate) valves or nozzles are connected here.

The by-pass connection of this unloader is a 1" NPTF sized port and is located on the bottom. There is an arrow and the word BY PASS cast into the body indicating the direction of flow. By-Pass fluid is directed out of this port and can be routed to a reservoir (preferred method), or to a drain or to the pump inlet.

OPERATION

This pressure sensitive regulating unloader holds established system pressure in the discharge line when the trigger gun is closed or solenoid (gate) valve is closed or the nozzle is clogged, thus by-passing all unrequired flow. Squeezing the trigger gun or opening the solenoid (gate) valve will close off the by-pass and return to established system pressure without delay.

PRESSURE ADJUSTMENT

1. Setting and adjusting the unloader pressure must be done with the system "on".
2. Start the system with unloader backed off to the lowest pressure setting (counterclockwise direction).
3. Squeeze the trigger and read the pressure on the gauge at the pump.

Note: Do not read the pressure at the gun or nozzle.

4. If more pressure is desired, release the trigger, turn pressure adjuster/adjusting handle one quarter turn in clockwise direction.
5. Squeeze the trigger and read the pressure.
6. Repeat this process until desired system pressure is attained.
7. Once the desired system pressure is reached, stop turning the pressure adjuster/adjusting handle.
8. Thread locking nut down to spring retainer.

Note: Locking nut is not set at the factory.

CAUTION: A minimum by-pass flow of 5% of the unloader rated flow capacity is required for proper unloader performance. If the entire out is directed through the unloader (zero by-pass) the "cushioning" feature of the by-pass liquid is eliminated and the unloader can malfunction or wear prematurely.

9. If desired system pressure cannot be reached, review TROUBLESHOOTING chart.
10. When servicing existing systems, back locking nut away from spring retainer.
11. Follow adjustment procedures as stated above for new unloaders.

Note: Do not adjust unloader pressure setting to compensate for a worn nozzle. Check the nozzle as part of the regular maintenance and replace if worn.

Note: A secondary pressure safety relief device (i.e. pop-off valve, safety valve) should be used along with this pressure sensitive regulating unloader. Final adjustment for the relief valve should relieve at 200 psi above the system operating pressure.

TYPICAL UNLOADER INSTALLATION

- 1 Relief Valve
Show as a secondary safety relief valve
- 2 Pressure Gauge
- 3 Triplex Plunger Pump
- 4 Pressure Sensitive Regulating Unloader
- 5 Pulsation Dampener

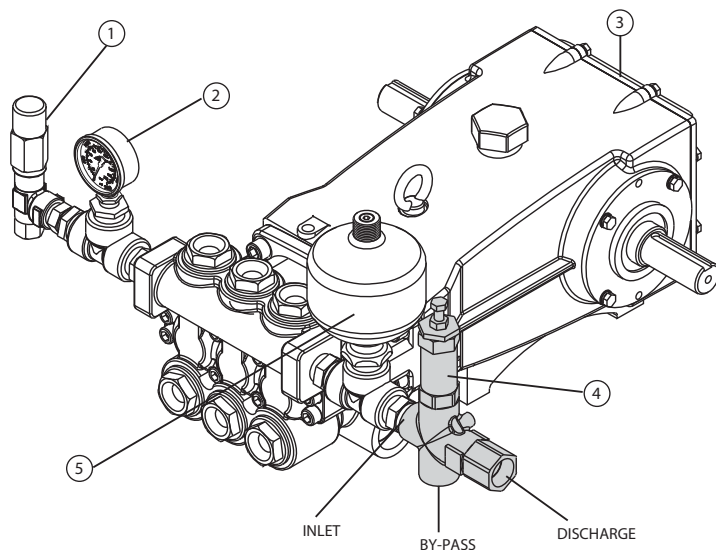

Read all CAUTIONS and WARNINGS before commencing service or operation of any high-pressure system

SERVICING

CAUTION: Before commencing with service, shut off drive (electric motor, gas or diesel engine) and turn off water supply to pump. Relieve all discharge line pressure by triggering gun or opening valve in discharge line.

Disassembly:

1. Disconnect by-pass, discharge and inlet plumbing from unloader.
2. Remove unloader from pump.
3. Secure lower body of unloader in a vise with pressure adjuster/adjusting handle facing up.
4. Remove discharge fitting and o-ring, spring, check valve and o-ring.
5. Inspect check valve and discharge fitting for wear, spring for wear or fatigue and o-rings for cuts or wear and replace as needed.

Note: While the discharge fitting is removed, inspect sealing area where the check valve makes contact within the internal body of the unloader for grooves, pitting and wear. If damage is found, stop the repair and replace with complete new unloader. If not, proceed with disassembly.

6. Unscrew and remove pressure adjuster/adjusting handle, locking nut, spacer (7592 only), spring retainer, upper spring retainer, spring, lower spring retainer and ball. Inspect all parts for scale build up or wear and replace as needed. Examine spring for fatigue or wear and replace as needed.
7. Unscrew upper body from lower body.
8. Secure the valve on the flat surfaces and using an 8mm allen wrench unthread the piston stem from the valve.
9. Remove piston retainer, o-rings and back-up-ring. Examine piston retainer for wear. Examine o-rings and back-up-ring for cuts or wear and replace as needed.
10. Examine the valve and piston stem for wear. Examine o-rings and back-up-rings for cuts or wear and replace as needed.
11. Press the seat out of the lower body from the by-pass port. Examine seat for grooves and o-ring for cuts or wear and replace as needed.

Reassembly:

1. Lubricate and install o-ring on outside diameter of seat and press seat squarely into position in the lower body.
2. Lubricate and install o-ring and then back-up-ring onto piston stem. Press piston stem with threads facing down into the top end of the upper body.
3. Lubricate and install back-up-ring and then o-ring into inside diameter of piston retainer. Insert piston retainer into the bottom of the upper body.
4. Apply Loctite® 242® to the threads of the piston stem and valve. Thread valve onto piston stem and tighten with wrench.
5. Lubricate and install o-ring on to bottom of the upper body. Carefully hand thread upper body into lower body and tighten with a wrench.
6. Replace the ball, lower spring retainer, spring, upper spring retainer, spring retainer and spacer (7592 only) into top of upper body.
7. Thread in locking nut and pressure adjuster/adjusting handle.
8. Lubricate and install o-ring onto check valve. Place spring inside check valve. Insert check valve with o-ring and spring into discharge port of lower body.
9. Lubricate and install o-ring onto threaded end of discharge fitting. Thread in discharge fitting to discharge port of lower body and tighten with wrench.
10. Remove unloader from vise.
11. Re-install unloader onto pump.
12. Reconnect by-pass, discharge and inlet plumbing to unloader.
13. Proceed to PRESSURE ADJUSTMENT.

Loctite® 242® are registered trademarks of the Henkel Corporation.

TROUBLESHOOTING

Unloader cycles	<ul style="list-style-type: none"> ● Check for leak downstream of unloader. ● Worn O-ring or check valve. ● Air in system, poor connection. ● O-ring in gun worn. ● Insufficient flow through unloader.
Liquid leaking from bottom fitting	<ul style="list-style-type: none"> ● O-ring for fitting cut or worn. ● O-ring for seat cut or worn.
Liquid leaking from middle	<ul style="list-style-type: none"> ● O-ring for piston worn or cut. ● O-rings for piston stem worn or cut.
Unloader will not come up to pressure	<ul style="list-style-type: none"> ● Not properly sized for system pressure. ● Foreign material in unloader. Clean filter. ● Piston stem O-rings worn. ● Nozzle worn. ● Insufficient flow to pump.
Extreme pressure spikes	<ul style="list-style-type: none"> ● Adjusting nut turned completely into unloader. ● Restricted by-pass or no by-pass. ● System flow exceeds unloader rating.
Filtration	<ul style="list-style-type: none"> ● Clean filter on regular schedule to avoid cavitation.

PRESSURE READING

Approximate Pressure Reading at Gauge	Gauge Between Pump/Unloader	Gauge Between Unloader/Gun-Nozzle-Valve
System in operation (gun open)	system pressure	system pressure
System in by-pass (all guns, valves closed)	low pressure 0-150 PSI	system pressure +200 PSI

EXPLODED VIEW

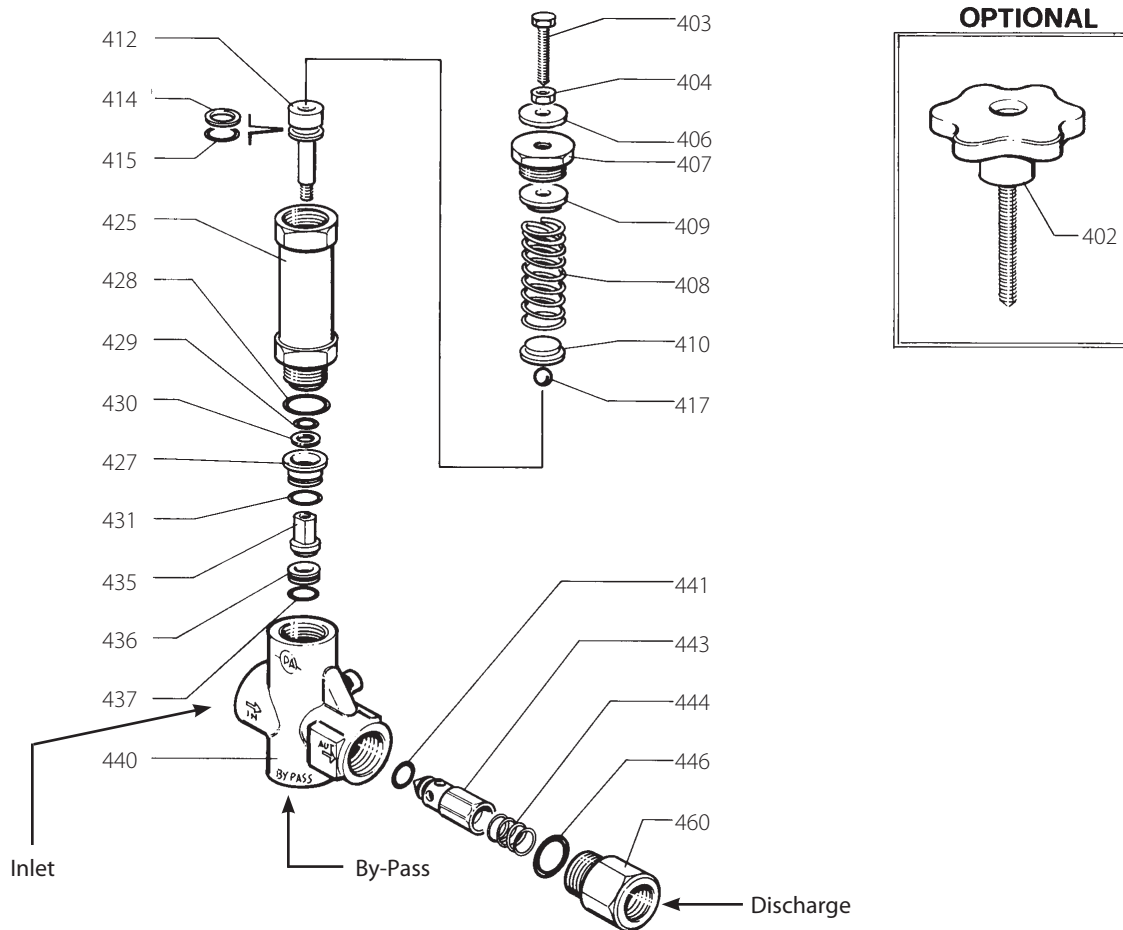

PARTS LIST

ITEM	PN	MATL	DESCRIPTION	QTY	ITEM	PN	MATL	DESCRIPTION	QTY
402	33089	NY	Handle, Adjusting w/Screw	1	429	—	NBR	O-Ring, Piston	1
403	39061	STZP	Adjuster, Pressure (M10x42)	1	430	—	PTFE	Back-up-Ring, Piston	1
404	—	STZP	Nut, Hex Locking (M10) (7590)	1	431	—	NBR	O-Ring, Piston Retainer	1
406	—	AL	Spacer (7592)	1	435	32774	S	Valve	1
407	39062	BB	Retainer, Spring	1	436	32775	S	Seat	1
408	39016	STL R	Spring (Silver)	1	437	32926	NBR	O-Ring, Seat - 95D	1
409	32781	BB	Retainer, Spring, Upper	1	440	—	BB	Body, Lower	1
410	32778	BB	Retainer, Spring, Lower	1	441	—	NBR	O-Ring, Check Valve	1
412	32776	S	Stem, Piston	1	443	32779	BB	Valve, Check	1
414	—	PTFE	Back-up-Ring, Piston Stem	1	444	32782	S	Spring, Check Valve	1
415	—	NBR	O-Ring, Piston Stem	1	446	—	NBR	O-Ring, Discharge Fitting	1
417	31075	SSSS	Ball, Seat	1	460	32780	BB	Fitting, Discharge (1" NPTF)	1
425	—	BB	Body, Upper	1	468	32773	NBR	Kit, O-Ring	1
427	32777	BB	Retainer, Piston	1				(Incls: 414, 415, 428, 429, 430, 431, 437, 441, 446)	
428	—	NBR	O-Ring, Upper Body	1					

Italics are optional items. R Components comply with RoHS Directive.

AL=Aluminum BB=Brass NBR=Medium Nitrile (Buna-N) NY=Nylon PTFE=Pure Polytetrafluoroethylene
S=304SS SSSS=440SS STL=Steel/Zinc Plated



CAT PUMPS

1681 - 94TH LANE N.E. MINNEAPOLIS, MN 55449-4324
PHONE (763) 780-5440 — FAX (763) 780-2958
e-mail: techsupport@catpumps.com
www.catpumps.com