



WW05 Series

Model 3872

SUBMERSIBLE SEWAGE PUMPS



FEATURES

Impeller: Glass-filled thermoplastic Full-Vortex design with pump out vanes for mechanical seal protection.

Casing and Base: Rugged glass-filled thermoplastic design provides superior strength and corrosion resistance.

Motor Housing: Cast iron for efficient heat transfer, strength, and durability.

Motor Cover: Thermoplastic cover with integral handle and float switch attachment points.

Bearings: Upper and lower heavy duty ball bearing construction.

Power Cable: Severe duty rated oil and water resistant.

O-ring: Provides positive sealing. Easily replaced during maintenance.

Stainless steel fasteners

AGENCY LISTINGS



By Canadian Standards Association

APPLICATIONS

Specifically designed for the following uses:

- Residential sewage systems
- Dewatering
- Water transfer

Anywhere waste or drainage must be disposed of quickly, quietly and efficiently.

SPECIFICATIONS

Pump:

- Solids handling capability: 2" maximum
- Capacities: up to 75 GPM
- Total heads: up to 18 feet
- Discharge size: 2" NPT
- Mechanical seal: carbon-rotary/ceramic-stationary, BUNA-N elastomers

- Temperature: 104° F (40° C) continuous, 140° F (60° C) intermittent
- Class B Insulation
- Fasteners: 300 series stainless steel
- Capable of running dry without damage to components.

Motor

- Single phase: ½ HP, 115 or 230 V, 60 Hz, 1550 RPM, built in overload with automatic reset.
- Power cord: 10 foot standard length, 16/3 SJTW with three prong grounding plug. Optional 20 foot length, 16/3 SJTW with three prong grounding plug.
- Fully submerged in high grade turbine oil for lubrication and efficient heat transfer.

Available for automatic and manual operation. Automatic models include Mechanical Float Switch assembled and preset at the factory.

MODEL INFORMATION

Order Number	HP	Volts	Amps	Minimum Circuit Breaker	Phase	Float Switch Style	Cord Length	Discharge Connection	Minimum On Level	Minimum Off Level	Minimum Basin Diameter	Maximum Solids Size	Shipping Weight lbs.kg
WW0511	.5	115	13	20	1	Plug / No Switch	10'	2"	Manual	Manual	18"	2"	22 / 10
WW0511A						Piggyback / Wide-Angle	10'		15"	9"			23 / 10.4
WW0511F						Plug / No Switch	20'		Manual	Manual			22 / 10
WW0511AC						Piggyback / Wide-Angle	20'		15"	9"			23 / 10.4
WW0512		230	6.5	10		Plug / No Switch	10'		Manual	Manual			22 / 10
WW0512F						Plug / No Switch	20'		Manual	Manual			22 / 10

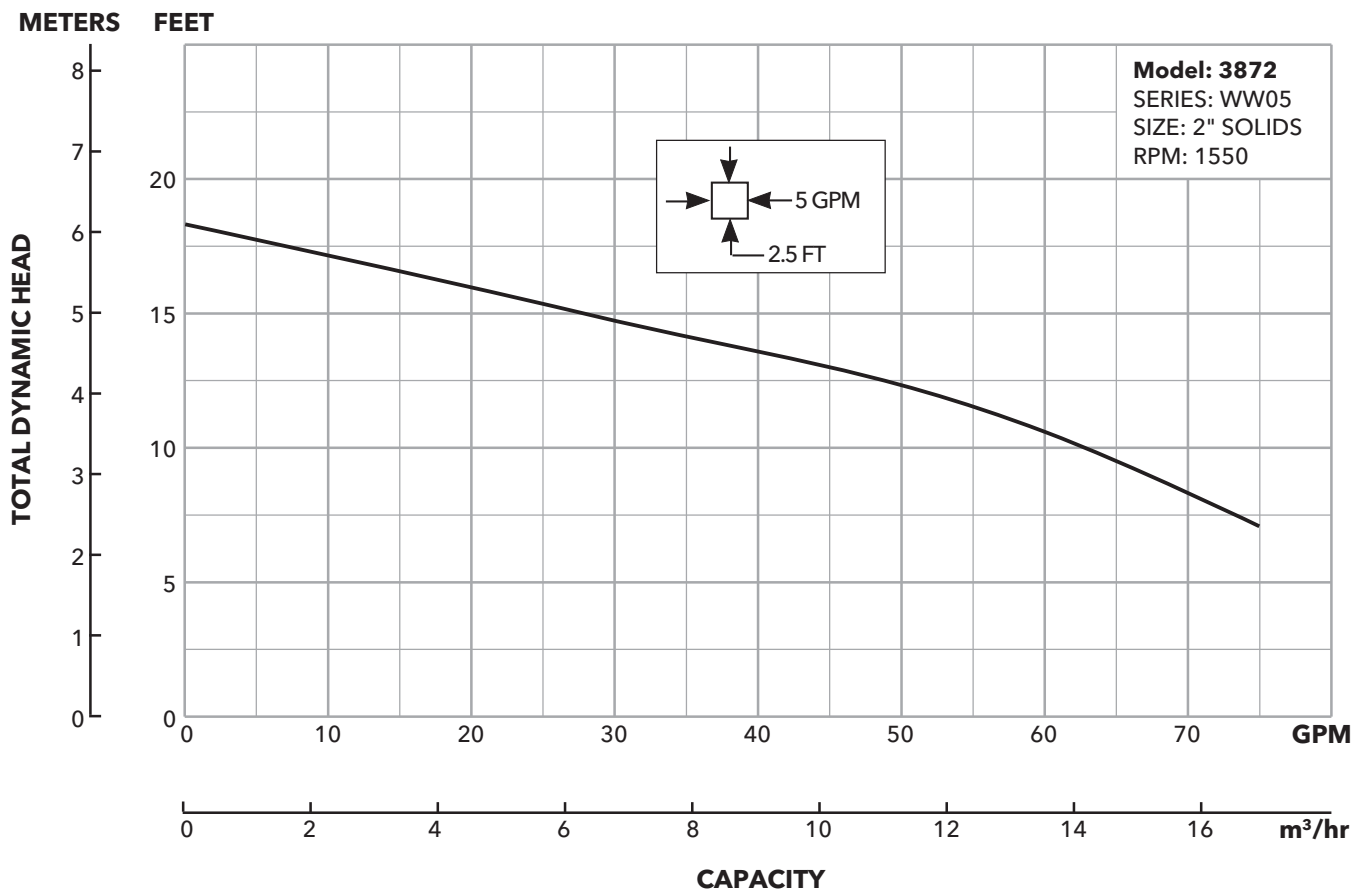

PERFORMANCE CHARTS

These charts show actual system performance with friction loss factored in for various discharge pipe lengths. Calculations and performance based on a system with 2" PVC, schedule 40 plastic pipe (C150), (4) 90° elbows, (1) check valve and (1) shut-off valve. Wastewater requires a minimum scouring velocity of 21 gpm for 2" pipe. Shaded areas do not provide min. scouring velocity - use only for gray water with no solids.

WW05 (3872)

	4	6	8	10	12	14	16
25	75	68	62	52	40	27	13
50	67	61	54	45	35	24	12
75	61	55	48	40	32	22	11
100	56	50	44	37	29	21	11
150	48	43	38	32	26	18	10
200	43	39	34	29	23	17	10
250	39	35	31	26	21	15	10
300	35	32	29	24	20	14	10

DIMENSIONS

(All dimensions are in inches. Do not use for construction purposes.)

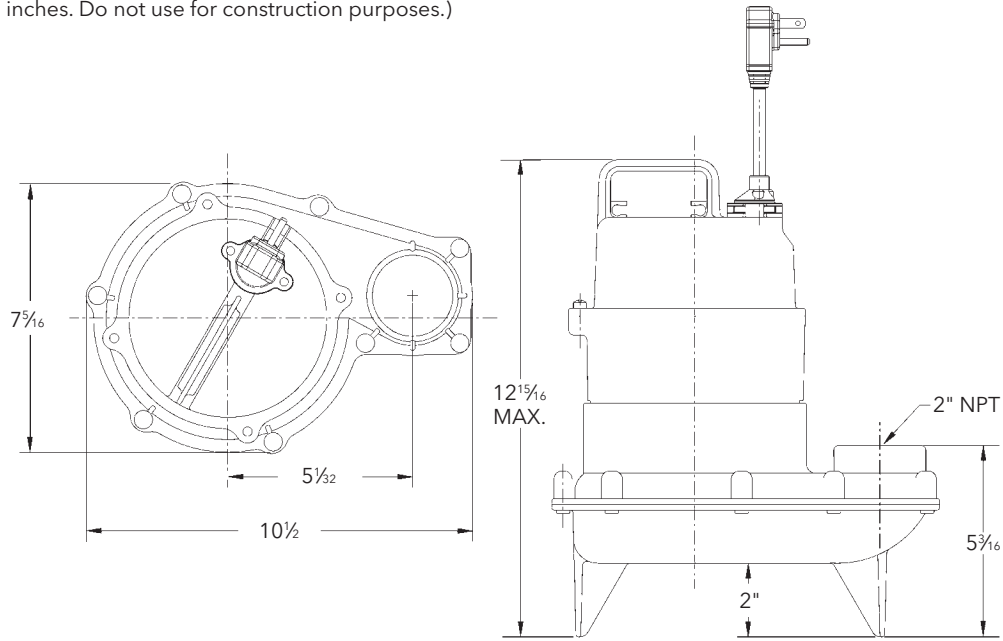

COMPONENTS *(for reference only)*

Item No.	Description
1	Impeller
2	Rugged thermoplastic base
3	Rugged thermoplastic pump casing
4	Mechanical seal
5	Ball bearings
6	O-rings
7	Power cord
8	Oil filled motor
9	Cast iron motor housing/stator assembly
10	Thermoplastic motor cover

* Parts available on repair parts selection chart.

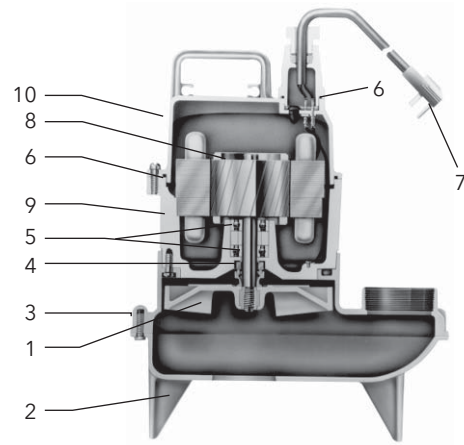

xylem
Let's Solve Water

Xylem Inc.
2881 East Bayard Street Ext., Suite A
Seneca Falls, NY 13148
Phone: (866) 325-4210
Fax: (888) 322-5877
www.gouldswatertechnology.com

Goulds is a registered trademark of Goulds Pumps, Inc. and is used under license.
© 2016 Xylem Inc. B3872 R2 September 2016