

SAMPLE COOLERS



Where Innovation Flows



The Neptune™ Sample Cooler is highly efficient in cooling hot water or steam samples for easy handling and effective sample collection. Applications include hot water, saturated steam and superheated steam services.

FEATURES AND BENEFITS

MODELS SC-316 & SC-600

- Rugged all-welded construction
- Internal baffles to ensure maximum heat transfer
- One square foot (0.3 sq. M) of heat exchange area

- Max pressure up to 3,500 psi (241 bar)
- Available in 316SS or with Inconel™ 600 coil and 316SS shell

MODEL SC-100 (CLEANABLE SAMPLE COOLER)

- Designed for simple removal of coil for inspection and cleaning
- Tubing tails which may be formed by a tubing bender for various angles of sample entry and exit
- Max pressure up to 1,500 psi at 600°F (103 bar at 316°C)
- Available in 316SS coil with carbon steel shell

Inconel is a trademark of Huntington Alloys Corporation

Specifications

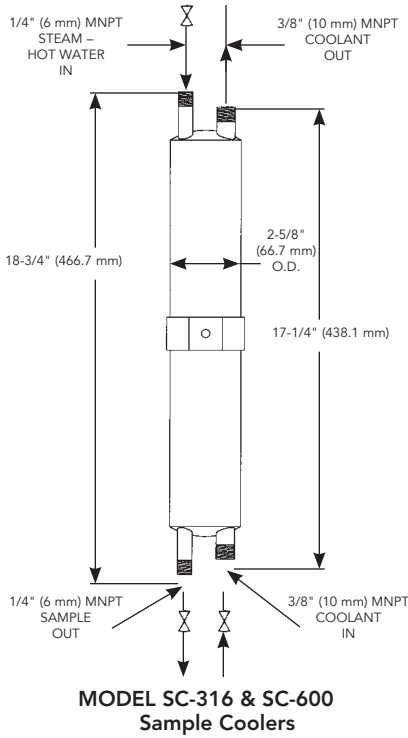

MODEL SC-316 & SC-600
Sample Coolers

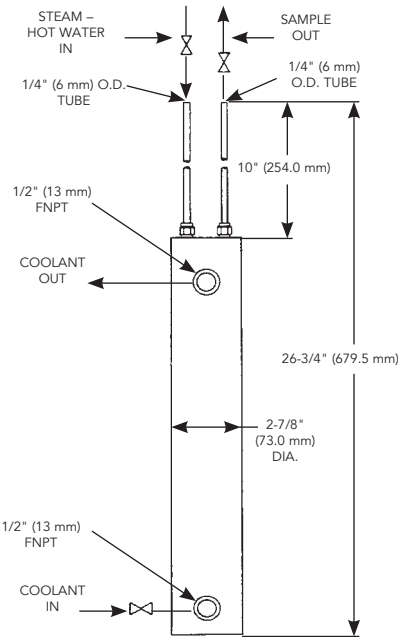

MODEL SC-100
Cleanable Sample Cooler

MODEL NUMBER	MATERIAL		PRESSURE RATING		WATER FLOW PRESSURE DROP	
			COIL	SHELL	COIL	SHELL
	COIL	SHELL	PSI (BAR)		PSI AT 250 LB./HR. (BAR AT 113 KG/HR.)	
SC-316*	316SS	316SS	3,500 (241)	250 (17.2)	55 (3.8)	3 (0.21)
SC-600*	Inconel 600	316SS	3,500 (241)	250 (17.2)	55 (3.8)	3 (0.21)
SC-100**	316SS	Steel	1,500 (103)	200 (13.9)	55 (3.8)	3 (0.21)

*Maximum Operating Temperature: 750°F (399°C)
**Maximum Operating Temperature: 600°F (316°C)

Performance

Assuming a coolant inlet of approximately 55°F (12°C), an exit of approximately 120°F (50°C) and a sample exit of approximately 110°F (43°C), the cooler will provide performance approximately per the ranges described below:

HOT WATER SAMPLES:

- At 250°F (120°C), approximately 1,500 CC/min of sample will be produced using 1 gpm (3.8 L/min) of coolant.
- At 700°F (370°C), approximately 950 CC/min of sample will be produced using 2-1/2 gpm (9.5 L/min) of coolant.

SATURATED STEAM VAPOR: The sample inlet and exit valves can be used to create various operating pressures in the cooler for producing samples from saturated steam vapor.

- At 175 psia operating pressure, 640 CC/min of sample can be produced using approximately 3.0 gpm (11.4 L/min) of coolant.
- At 25 psia operating pressure, 300 CC/min of sample can be produced using approximately 1.5 gpm (5.7 L/min) of coolant.

SUPER HEATED STEAM: Maximum sample inlet temperature of 750°F (400°C). (See chart below.)

- 1,000 psia cooler operating pressure produces 640 CC/min of sample at 3.5 gpm (13.3 L/min) coolant flow.
- 20 psia cooler operating pressure produces 315 CC/min of sample at 1.75 gpm (6.6 L/min) coolant flow.

Installation

Proper installation requires valves on sample inlet and cooling water inlet for hot water service. An additional valve must be installed on the sample outlet for all vapor or steam services to obtain required operating pressures in the coil.

Proper installation in superheated steam service also requires precooling the sample to 750°F (399°C), the maximum design operating temperature of the Neptune Sample Cooler.

Precooling can be accomplished by installing a pipe between the main steam header and the sample cooler to radiate excess heat. The length of the pipe is determined from the chart at right.

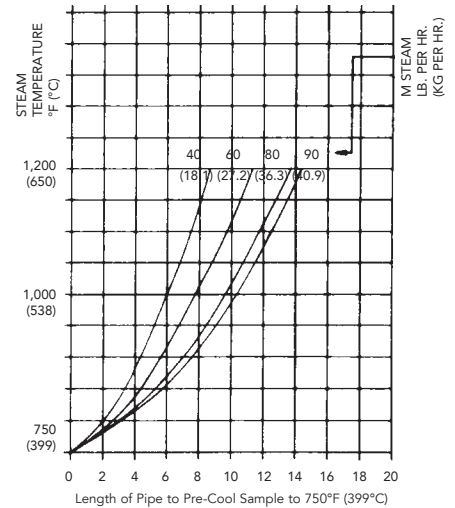

Where Innovation Flows



Distributed By:

PSG
22069 Van Buren Street
Grand Terrace, CA 92313-5651 USA
P: +1 (909) 422-1730 • F: +1 (909) 783-3440
psgdover.com/neptune